

B.M.C. Audio DAC 1 Quick Start

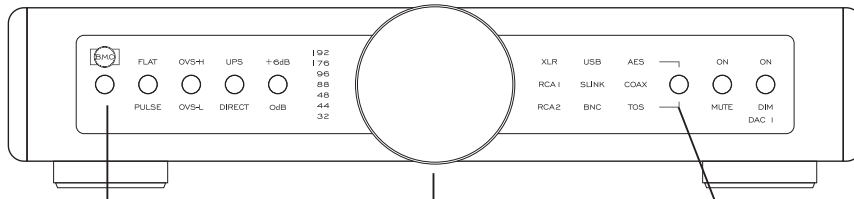

DAC 1 OWNER'S MANUAL



Power on/off the unit
Set Volume
 (Volume control, for B.M.C. power amplifier with DIGM and / or optional preamplifier module)

Detailed description of options inside the owner's manual.

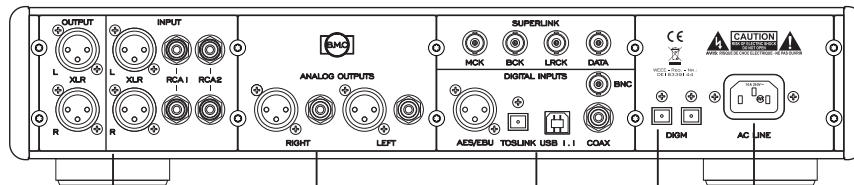

PreAmp-Module (Optional)
 Balanced and RCA analogue inputs.
 Balanced output for connecting to power amplifiers or active speakers.
 Configurable either for DIGM amplifier compatibility or as traditional pre-amplifier.

Analog Outputs
 Fixed Level
 For connecting amplifiers

Digital-Inputs
Superlink
 SPDIF
 AES/EBU
 TOSLINK
 COAX
 BNC

USB 1.1

AC Line
 Make sure the lokal AC power voltage fits to the printed voltage.

DIGM
 for Gain Managment of B.M.C. Power Amplifiers

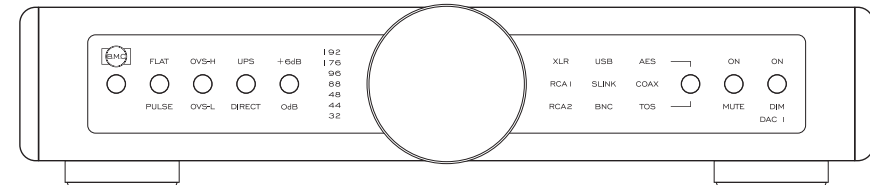

Find a detailed description and illustration inside this owner's manual.

Table of Content

Introduction, Content of Packing	3
Front Panel Functions	4
Rear Panel Description	5
Digital-Filter-Options	6
Volume Control, Variable Output	7
Interconnection Options - SUPERLINK, SPDIF, USB	8
Remote Control Handset	9
Troubleshooting, Maintenance, Service	10
Important Safety Information	11
General Safety Precautions	12
CE / FCC-Declaration, Recycling	13
Attachment: Jumper Settings	14
Technical Specifications DAC1	15
Quick Start	16

Technical Specifications DAC1

Frequency Response 20Hz – 20kHz DF Flat	+0 / - 0.25dB
Frequency Response 20Hz – 20kHz DF Pulse	+0 / - 1.75dB
Output Impedance	50 Ohm
Output Voltage (RMS) at 0dBFS, XLR	4Vrms
THD+N, OVS-L	
0dBFS	0.006 %
-6dBFS	0.004 %
-10dBFS	0.003 %
-20dBFS	0.006 %
THD+N, OVS-L	
0dBFS, +6dB	0.007 %
THD+N, OVS-H	
0dBFS	0.013 %
-6dBFS	0.008 %
-20dBFS	0.007 %
THD+N, UPS	
0dBFS	0.014 %
-6dBFS	0.012 %
-20dBFS	0.01 %
THD+N, PreAmp	
4Vrms	0.004 %
2Vrms	0.0009 %
1Vrms	0.0008 %
Noise	
OVS-L	-110dB
UPS	-109dB
PreAmp	-130dB
Power Consumption	16-20 W
Dimension Enclosure (W x H x D)	435 x 78 x 320mm
Dimensions incl. Knobs, legs, terminals	435 x 91 x 350mm
Weight	8.5 Kg

Note: Technical specifications are subject of change without notification. All specifications without warranty.

Technical specifications just have a limited meaning about the overall quality. The main purpose is to ensure some technical standards, but better specs not necessarily result in better sound quality.

Although B.M.C. audio always put highest priority on sound quality and just use negative-feedback-free circuitry, excellent technical specifications have been achieved.

B.M.C. AUDIO GmbH D-34123 Kassel Erlenfeldweg 39
Telefon: 0561 / 47398150 Fax: 4751469
WWW.BMC-AUDIO.DE INFO@BMC-AUDIO.DE

Attachment: Jumper Settings

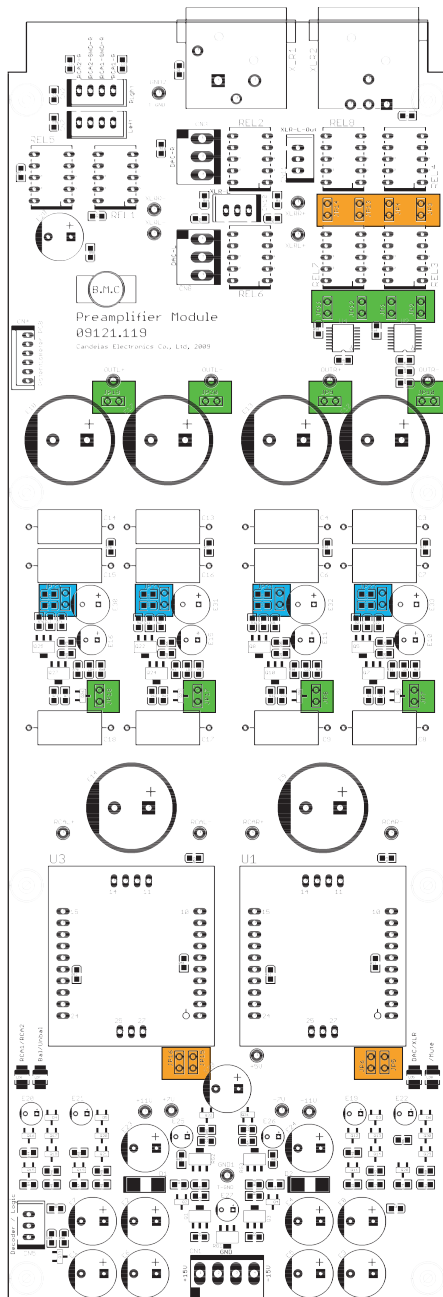

For safety reasons only qualified service personnel is permitted to change jumper settings!

Switch off the unit and disconnect the power cable each time before changing the jumper setting!

ORANGE: Loop-Through Mode

For Loop-Through Mode plug jumpers JP3, JP4, JP5, JP6, JP13, JP14, JP15 and JP16.

Loop-Through Mode is intended to be used for connecting with an amplifier having an adjustable volume. BMC amplifiers have a lossless gain control, BMC power amplifiers can be controlled via optical DIGM interface by this DAC1.

GREEN: PreAmpl Mode

For PreAmpl Mode with volume control inside this module, plug jumpers JP1, JP2, JP7, JP8, JP9, JP10, JP11, JP12, JP17, JP18, JP19 and JP20.

PreAmpl Mode is intended for use with conventional power amplifiers and active speakers.

BLUE: DC Mode

For DC Mode plug jumpers JP21, JP22, JP23 and JP24.

These jumpers allow to DC couple the output of the digital potentiometer. Without the jumper the output is AC coupled.

AC operation may reduce "zipper-noise" during volume setting. DC coupling is the direct pathway and thus offers sonic advantages.

In Loop-Through Mode, these jumpers have no influence.

Introduction

Thank you for purchasing B.M.C.'s DAC1 and congratulations for choosing this exceptional component! We also like to thank you for supporting the puristic SUPERLINK interconnection system by this purchase.

It makes more sense and thus it is easier to reduce jitter when having the "Master-Clock" inside the Digital to Analogue converter, just the way SUPERLINK is doing. The separate transmission of the "Master Clock", "Bit Clock", "Left-Right Clock" as well as the audio data also avoids degradations by coding and later decoding such signals into a single stream, like SPDIF transmission is doing. As long as your CD-transport supports SUPERLINK this is the best interconnection to a DAC.

Additionally to the SUPERLINK concept sophisticated clock-synchronisations for the digital audio signal keep the signal quality on the highest level.

One key for the exceptional sound quality is the global-feedback-free analogue section. With its CI-input (CI = Current Injection) input the DAC-chip get the optimum interface and the extremely fast circuit is insensitive to digital noise, preserving all musical information. The LEF output driver delivers a stable output signal, again without a sound degrading global feedback loop. LEF (Load Effect Free) is a balanced, cascoded, single-ended-class-A circuit with a separate delivery of signal voltage and signal current.

With DAC1's DIGM-controller feature it is possible to achieve a high-end audio system with very short signal path, by connecting a B.M.C. power amplifier via the fixed level outputs and adjusting the volume by losslessly changing the power amplifier's gain through DAC1's volume knob. For high end audio systems with digital sources exclusively the DAC1 handles all preamplifier functions.

Optionally an additional preamplifier module is available, featuring 2 RCA and one balanced XLR analogue inputs in addition to the digital inputs. A balanced XLR output interconnects to power amplifiers, active speakers or subwoofer. The preamplifier module offers two different operation modes:

- Traditional preamplifier function with volume control.
- Super short signal path for the use with DIGM amplifiers.

Content of Packing

DAC1

AC Power Cable

Remote Control Handset + 2 AAA-Batteries

Owner's Manual

It is recommended to keep the packing for eventual later transportations.

Front

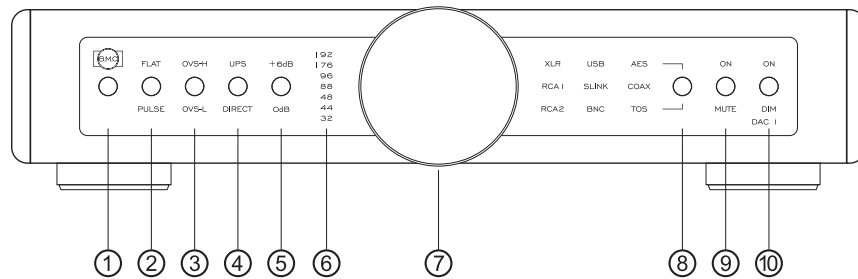

- ① **POWER**
Press for powering the unit on and off.
- ② **Digital Filter**
Toggle the digital filter characteristic between frequency response optimised "FLAT" or the dynamic response optimised "PULSE".
- ③ **Oversampling**
Toggle between low oversampling "OVS-L" and high oversampling proceeding "OVS-H".
- ④ **Sample Rate Converter**
Select between a direct digital signal processing path (DIRECT) or the use of an asynchronous upsampler (UPS).
- ⑤ **DAC Output Level**
Choose between standard output level (0dB) or a higher level if in case needed. Increase level may cause distortions within the following connected component.
- ⑥ **Sampling Frequency**
Displays the incoming sampling frequency
- ⑦ **Volume**
Adjust the volume level for either a connected B.M.C. power amplifier managed with the optical DIGM line and /or the optional preamplifier module.
- ⑧ **Input Selector**
Press for changing the active input. Each press moves up one input step.
- ⑨ **MUTE**
Key for signal mute and de-mute.
- ⑩ **DIM**
Change the display brightness between normal and dimmer.

CE / FCC declaration, Recycling

CE Declaration of Conformity

B.M.C. AUDIO GmbH declares that this product is in conformance with the Low Voltage Directive 73/23/EEC and Electromagnetic Compatibility 89/336/EEC as amended by 92/31/EEC and 93/68/EEC.

The conformity of this product with the regulations of Directive number 73/23/EEC (LVD) is proved by full compliance with the following standards:

Standard number	Date of issue	Test type
EN60065	2002	General requirements
		Marking
		Hazardous radiation
		Heating under normal conditions
		Shock hazards under normal operating conditions
		Insulation requirements
		Fault conditions
		Mechanical strength
		Parts connected to the mains supply
		Components
		Terminal devices
		External flexible cords
		Electrical connections and mechanical fixings
		Protection against electric shock
		Stability and mechanical hazards
		Resistance to fire

The conformity of this product with the regulations of Directive number 89/336/EEC (EMC) is proved by full compliance with the following standards:

Standard number	Date of issue	Test type
EN55013	2001	Conducted emissions
EN55013	2001	Absorbed emissions
EN55020	2002	Immunity

FCC notice

Note: This equipment has been tested and found to comply with the limits for Class B digital devices, according to Part 15 of the FCC Rules. These limits are designed to provide reasonable protection against harmful interference in a residential installation. This equipment generates, uses and can radiate radio frequency energy and, if not installed and used in accordance with the instructions, may cause interference to radio communications. There is no guarantee that interference will not occur in a particular installation. If this equipment does cause harmful interference to radio or television reception, which can be determined by turning the equipment off and on, the user is encouraged to try to correct the interference by one or more of the following measures:

- Connect this unit to a different outlet than the receiver.
- Relocate or reorient the receiving antenna.
- Increase space between this equipment and receiver.
- Consult your dealer or an experienced radio/TV technician.



Waste Electrical and Electronic Equipment (WEEE) Directive

Waste Electrical and Electronic Equipment Directive Directive 2002/96/EC of the European Parliament and of the Council.

The bin symbol is shown on this product. It indicates that the product should not be disposed of with regular household waste, but should be disposed of separately.

Electrical and electronic equipment may contain materials that are hazardous to the environment or human health and therefore should be disposed of at a designated waste facility or returned to your retailer for appropriate recycling.

If you wish to dispose of this unit and it still functions, please consider recycling/reusing it by selling it, trading it in at your dealer for new equipment, giving it away to friends or donating it to a charity shop.

General Safety Precautions

1. Read this owner's manual.
2. Keep the owner's manual.
3. Pay attention to all important safety information and warnings.
4. Follow the manual instructions.
5. Never use the unit close to water or in a humid surrounding, like wash sinks, a humid basement, swimming pools...
6. For cleaning use a dry exclusively.
7. Do not block any ventilation openings. Install in accordance with the manufacturer's instructions. If placed in a shelf make shure to keep about 10cm to each side and 20cm to the top. Do not place the unit in a way covering the bottom plate like a sofa, a bed, thick carpets or blankets.
8. Do not install the unit near any heat sources such as radiators, heat registers, stoves, or other apparatus (including amplifiers) that produce heat.
9. Do not spoil the safty meaning of earthed AC power cables! The earth contact pin serves your safety. In case the attached cable does not match to your AC-Line wall socket, please ask an electrician to replace such outdated wall outlet.
10. Protect the unit's power cord from being walked on or pinched, especially around the plugs, convenience receptacles, and where it exits DAC1's casing.
11. Only use attachments/accessories specified by the manufacturer.
12. Only use the unit with a cart, stand, tripod, bracket, or table specified by the manufacturer or sold with the unit. If using a cart, exercise caution when moving the cart unit combination to avoid injury from it tipping over.
13. Unplug the unit during lightning storms or when leaving it unused for extended periods of time.
14. Refer all servicing to qualified service personnel. Servicing is required when the DAC1 itself, its power-supply cord, or plug has been damaged in any way, when liquids have been spilled onto the unit, when foreign objects have fallen into the unit, when the unit has been exposed to rain or moisture, when the unit does not operate normally, or when the unit has been dropped.
15. Plug the AC power cord into an easily accessible AC wall outlet, so it can be quickly unplugged in case of emergency.
16. Remove the AC wall plug for seperating the unit from the AC power line. The AC plug should always be accessible.
17. Do not expose the unit to drips or splashes. Do not place any objects filled with liquids, such as vases, on the unit.
18. Do not place any open fire close to the unit, like candles.
19. DAC1 was designed to work properly in a temperature range from 10°C to 30°C and a maximum of 80% humidity.

Rear Panel Description

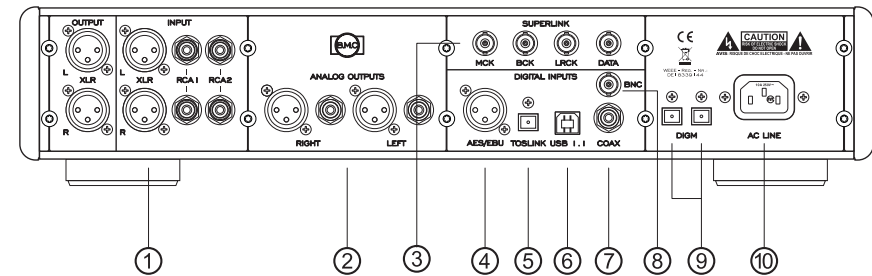

Analogue Outputs

- ① **Optional PreAmp-Module**
Balanced (XLR) and un-balanced (RCA) inputs; balanced XLR output with either fixed level for DIGM use, or variable level for preamplifier use.
- ② **DAC Analogue Output**
Fixed level balanced (XLR) and un-balanced (RCA) outputs.

Digital Inputs

- ③ **SUPERLINK**
Highest Level digital interconnection using 4 BNC cables with 75-Ohm for CD-players with compatible Superlink interface.
- ④ **AES/EBU**
Balanced AES/EBU digital input for 110-Ohm XLR cable.
- ⑤ **TOSLINK**
Optical TOSLINK-input
- ⑥ **USB**
USB terminal for connection with computer.
- ⑦ **COAX**
Coaxial digital input for 75-Ohm RCA cable.
- ⑧ **BNC**
Coaxial digital input for 75-Ohm BNC cable.
- ⑨ **DIGM**
Optical terminal for propiatory control of B.M.C power amplifiers.
- ⑩ **AC LINE**
Power cord terminal. Connect only if the indicated AC line voltage matches to your local voltage.

Digital Filter Options

Digital-Filter

The **FLAT** filter delivers most linear frequency response, but shows pre- and post-ringing in dynamic response. Pre-ringing does not exist within the analogue world.

The **PULSE** filter is almost ringing free and thus optimised for dynamic response, but has a slight roll-off damping at the top end of the frequency range.

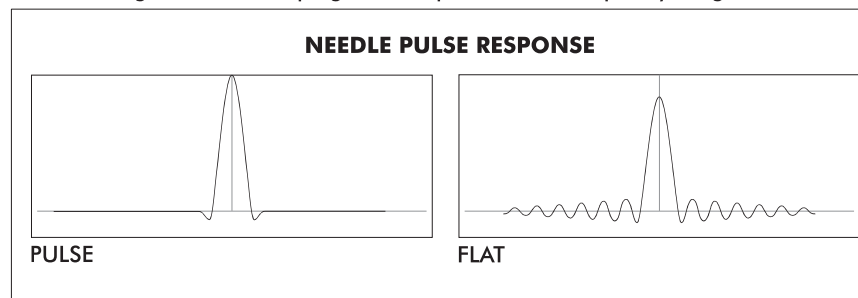

Oversampling

The lowest oversampling setting **OVS-L** delivers the most dynamic music performance with lowest distortions.

The highest oversampling setting **OVS-H** has a slightly smoother and more quiet sound characteristic.

Upsampling (Sample-Rate-Converter) / Direct

The **DIRECT** proceeds the digital signal with its original clock. This is recommended for low-jitter sources.

UPS adds an asynchronous up-sampler and creates a new clock-base with 96kHz. This way a very low jitter can be achieved even for poor sources (i.e. DVD player). For the high grade interconnection SUPERLINK the UPS option is not available.

0dB / +6dB

0dB = Standard output level with max. 2Vrms at RCA, 4Vrms at XLR.

+6dB = Increased output level, for the use low sensitivity power amplifier.

Note: Not every amplifier input can accept higher than standard levels without causing distortions.

Important Safety Information

Description of used symbols:

The lightning flash with arrowhead symbol, within an equilateral triangle, is intended to alert the user to potential shock hazards within the product's enclosure.



The exclamation point within an equilateral triangle, is intended to notify the user to the presence of important operating and maintenance (servicing) instructions in the accompanying documentation.



CAUTION:

TO REDUCE THE RISK OF ELECTRIC SHOCK, DO NOT REMOVE THE COVER OR REAR PANEL. IT DOES NOT CONTAIN ANY USER-SERVICEABLE PARTS. REFER SERVICING TO QUALIFIED SERVICE PERSONNEL.

ANY FUSE WITHIN THE PHONO MCCI SHOULD JUST BE REPLACED BY QUALIFIED SERVICE PERSONNEL. REFER SERVICING TO QUALIFIED SERVICE PERSONNEL ONLY.



WARNING :

TO PREVENT FIRE OR SHOCK HAZARD, DO NOT EXPOSE THIS APPLIANCE TO RAIN OR MOISTURE.

Power Cord

The unit is equipped with a power cable matching to the local AC power line sockets in the country of sale. Just the attached power cord is specified for the use with BDCD1.

In case of questions please ask an electrician.



Troubleshooting

Whenever you suspect a malfunction of the unit, please first check a possible cause by proceeding the below list, before contacting the B.M.C. service.

No Function or Display

- Check the AC-power cable is connected at both sides.
- make sure there is AC power available at the wall outlet.
- Check the power switch position.

No playback, distorted or interrupted playback

- Check whether the digital signal is not coded PCM (AC3, DTS...).
- Check the source interconnection.
- In case of CD: Check the disc for scratches and dirt.
- In case of USB: Check the computer's sound settings.
- In case of distortions: Set the DAC to 0dB output level.
- Take care the unit is placed on a solid, low-vibration location.
- Check the interconnection to the following component.
- Check the amplifier's input setting.

Remote control non-functional

- Point with the remote handset to the remote sensor close to the power switch.
- Replace the remote handset batteries.

Note: Like any other CD player the DAC1 has micro-computers inside which may "hang-up" due to static discharge or other voltage sparks. In this case power off the unit, wait for about 30 seconds and power on again.

Maintenance

- BDCD1 requires no user maintenance.
- Clean the unit with a dry micro-fiber cloth only.
- Take special care not to scratch the acrylic windows.

Service

In case you have to contact the B.M.C. service centre, please prepare the following information:

- Model-name and serial number.
- Date of purchase.
- Name, tel. and address of the dealer.
- Precise description of the malfunction.

Volume Control / Variable Output

⑦ (Front) DAC1 offers a lossless volume control of a remote B.M.C. power amplifier. The amplifier is connected via XLR interconnection from the fixed outputs and additionally an optical Toslink cable connects the DIGM terminals of DAC1 and the B.M.C. amplifier. The optical lines sends a control signal to the amplifier, so the DAC1 can set the volume via the precise and lossless DIGM feature, as well as transmit some other commands.

Optional: PreAmp-Module

① (Rear view) DAC1 optionally can be equipped with a preamplifier module. In addition to the digital inputs this module offers 3 analogue inputs (balanced XLR + 2 x RCA). The preamp-module can be configured to match for DIGM operation mode instead of classical preamplifier mode. This makes the signal path very short and improves the sound quality. Same as above the volume of any analogue source is set by the DIGM inside the B.M.C. power amplifier. Another way of using the preamplifier-module is the classical way, featuring a precision resistor-network potentiometer and a single-ended class-A LEF output driver. This way the output can be connected tonon-B.M.C. power amplifier or active speaker. It is also possible to use this output for connecting with a RCA input amplifier, by using an adaptor which does not transmit the inverted signal channel.

The internal configuration of the preamplifier module should be either specified when ordering or made by a qualified service person, according to the attachment "Jumper Settings" on page 14 of this manual. Please advise your service person to follow the instructions on page 14.

For safety reasons such changes should not be done by an end user.

Pin Configuration of the XLR Terminals

Please take care not to reverse the phase when using XLR interconnections, by checking with the below table.

For all B.M.C. units the below configuration is standard:

PIN 1 = GND / Ground

PIN 2 = + / Hot / 0°-Phase (non-inverted)

PIN 3 = - / Cold / 180°-Phase (inverted)

Interconnection Options

SUPERLINK consequently transmits all necessary digital audio clock- and data-signals separately. The "Master-Clock" is inside the DAC unit and located close to the dac section, so transportation loss Jitter does not occur.

This interconnection delivers the highest level of naturalism in sound quality and makes expensive SPDIF interconnection cables obsolete.

The connection terminals on the rear panel of the CD transport as well as the DAC are marked as followed: MCK, BCK, LRCK and DATA.

Before connecting any cable make sure both units are powered off and the AC-line cable is disconnected!

For each interconnection use a 75-Ohm BNC cable and connect identically marked terminals only. The included BNC cables have been tested for proper function and deliver an excellent sound quality.

In SUPERLINK the "Master-Clock" is inside the DAC unlike when using any other operation mode the "Master-Clock" is within the CD transport. Due to this difference in operation the CD transport must restart whenever changing the DAC input to SUPERLINK or from SUPERLINK. Automatically the CD transport will restart and after reading the TOC remain idle. for starting playback PLAY must be pressed.

SPDIF

SPDIF (Sony/Philips-Digital InterFace) is the common standard for digital audio transmission. It is used with 75-Ohm BNC or RCA connections, optical connections as well as a professional AES/EBU 110-Ohm version.

USB

USB1.1 terminal for playing back any sound from a computer. There is no driver installation required and the input works with all major operation systems. For Windows OS the use of a direct streaming driver is recommended.

Use high grade, shielded USB-2.0 cables without ferrite cores exclusively.

Remote Control Handset

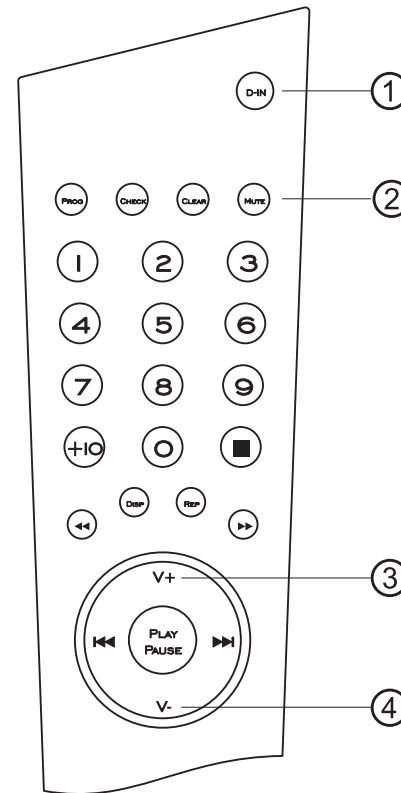

- ① **DAC1 Input**
Select digital inputs: AES, COAX, USB, S.LINK, BNC... as well as the optional (with preamp module) analogue inputs: XLR, RCA1, RCA2.
- ② **Mute**
Toggle signal mute and play.
- ③ **V+ Volume +**
- ④ **V- Volume -**
Volume control for connected DIGM compatible power amplifier and / or the optional preamplifier module's variable output level.

The keys without description relate to the BDCD1.

Whenever that usable range of the remote control gets smaller the batteries should be replaced with new AAA type ones. Insert the batteries according to the marking inside the battery holder.

CAUTION: Batteries may explode when putting into fire!
Displace used batteries according to you local recycling laws.