



**LINDEMANN.**  
high fidelity excellence



# 832

Stereo Control Amplifier

Owner's Manual

ENGLISH

## Important Safety Precautions

- Use only an approved power cable and plug or distribution board to connect your amplifier to a power outlet. Do not use an extension cable.
- Never touch the mains plug if your hands are wet.
- Do not attempt to open the equipment. Refer servicing and repair to qualified service personnel. Touching live components inside the case can result in a fatal electrical shock!
- Read the Owner's Manual and Safety Precautions before operating the equipment.
- Keep this Manual in a safe place so that you can refer to it later.
- Please heed all warnings on the equipment itself and in the Owner's Manual.
- Please follow the instructions contained in your Owner's manual and never use this equipment for any purpose other than is explained in this Owner's Manual.
- Only connect this equipment to a power source of the type described in the Owner's Manual and specified for this equipment.
- Make sure that there is adequate ventilation around the equipment to allow proper cooling. Keep the equipment away from direct sunlight. Avoid installing the unit close to sources of heat or in spaces such as bookshelves or cupboards where heat radiation may be obstructed. Avoid excessive temperatures in the room, as these could ultimately damage sensitive components and reduce the service life of your player.
- Never use the unit in damp rooms, at temperatures of below 15°C, or in the open air. When bringing your amplifier in from the cold, allow it time to achieve room temperature before plugging it in.
- Always switch the unit off before removing or inserting interconnects. Doing this with the amplifier switched on can damage not only the amplifier itself but also equipment connected to it.
- If you ever spill water or any other liquid onto the equipment: Do not touch the case! Remove the plug from the wall outlet and contact your dealer or our service department.
- Never remove the earth connection from the plug. It is there to ensure your safety.
- Arrange the power cable so that no one can accidentally stand on it. Avoid locating it under objects that might put pressure on the cable. Pay particular attention to areas where the cable exits from plugs, AC outlets and from the unit itself.
- Never operate the unit without being present. Disconnect the plug from the wall outlet and remove all aerial connections (including cable aerials) when: you clean the unit, you do not expect to use the unit for long periods of time, during an electrical storm.
- If you have an external antenna or cable antenna connected to your hi-fi system, we recommend that you use a signal isolating filter to avoid interference or damage during thunderstorms.
- Problems: If you lose the sound while the amplifier is operating, or if you notice smoke or burning, switch the unit off immediately and contact your dealer or our service department.
- Only replace defective fuses after you have traced and removed the cause of the fault and then only with a fuse of the same rating. Remove the mains plug before changing fuses. Use an insulated screwdriver to remove and replace the fuse.

## Dear Music Lover,

Congratulations on becoming the owner of this new Control Amplifier. The 832 is an exclusive high-end audio component, built in Germany in limited quantities.

Our team designed this control amplifier to the highest standards so that you could enjoy the highest level of audio reproduction. Because we use only the finest components and the most modern production technologies, we confidently guarantee that our products will retain their superb qualities for many years.

Keep the carton and packaging materials that your 832 came in. They will protect your control amplifier should you need to transport it in the future. Transporting the 832 in anything other than the original packaging may result in physical damage not covered by your warranty.

A final note: Please take the time to read this Owner's Manual before using the equipment for the first time. It contains a number of useful tips gathered from our many years of experience, which will help you get the most from your hi-fi system.

## Copyright and trade mark acknowledgements

This manual is provided for informational use only. Its content is subject to change without notice and should not be construed as a commitment on the part of Lindemann audiotechnik GmbH. The publisher assumes no responsibility or liability for any errors or inaccuracies that may appear in this manual.

### **Copyright and trademark information**

Copyright © 2007 Lindemann audiotechnik GmbH. All rights reserved.

No part of this publication may be reproduced, stored in a retrieval system or transmitted, in any form or by any means, electronic, mechanical or otherwise, without the prior written permission of the publisher.

## Table of Contents

Copyright and trade mark acknowledgements	3
Table of Contents	4
Accessories supplied	4
Front view	6
Rear view	8
Remote control	10
Using the 832 for the first time	11
Basic preamplifier controls	12
Switching on and off	12
Input select	12
Adjusting the volume	13
Balance	13
Mute	13
Configuration menu	14
Balance	15
Gain	15
Monitor	15
Volume display	16
Max. volume	16
Mute level	16
Absolute phase	16
Display brightness	16
Reset to default (factory settings)	16
Inputs	17
Name (input name)	17
Enable (activating inputs)	17
Pre Gain (input sensitivity)	17
Phase	17
Fix to 0dB (bypass)	18
Link Mode	18
Troubleshooting	19
Specification	20
CE declaration of conformity	21
Guarantee and Service	22
Directive on waste electrical and electronic equipment	23

## Accessories supplied

- 832 Stereo Control Amplifier
- Power cable, 2 metre
- SYSCOM cable, 1 metre
- Owner's Manual

We recommend that you keep the packaging for use when transporting the 832 in the future.

- Place your control amplifier on a stable support and use a spirit level to make sure it is perfectly level. We recommend the use of a solidly constructed hi-fi rack with adjustable shelves. In our experience, you will achieve good results with racks using MDF shelves. Glass, metal or stone being less suitable for use as hi-fi equipment supports. Avoid placing the control amplifier close to loudspeakers or any other source of vibration. The 830 will respond to these measures by performing at its best. Never stack the 830 directly on other items of equipment. Vibrations from mains transformers and electromagnetic interference from other components can have a negative impact on the control amplifier's sound quality. 800 series products are not suitable for installation in enclosures such as 19" racks or cabinets. The on/off switch at the rear of the unit must always be accessible.
- Take some time to organize your cabling. Try to keep power cables away from interconnect and speaker cables. Shielded power cords can significantly reduce the transfer of interference to your signal cables.
- Make sure that the polarity of the mains wiring is the same for all system components. You can achieve this by connecting all system components through a **single** high quality mains distribution board. The lower the contact resistance between the power outlets of your signal source and your control amplifier, the less the audio signal will be polluted and the better your hi-fi system will sound. Connecting your components with the correct mains polarity is particularly important. Use a phase tester to determine which pole is live. Mark the appropriate side.
- Cleaning and maintenance: To clean your control amplifier, use a soft cloth. Use a proprietary glass cleaner to remove stubborn dirt from the front panel. Do not use water! Never use solvents or white spirit. These will cause irreparable damage to the surface of the unit.

## Front view

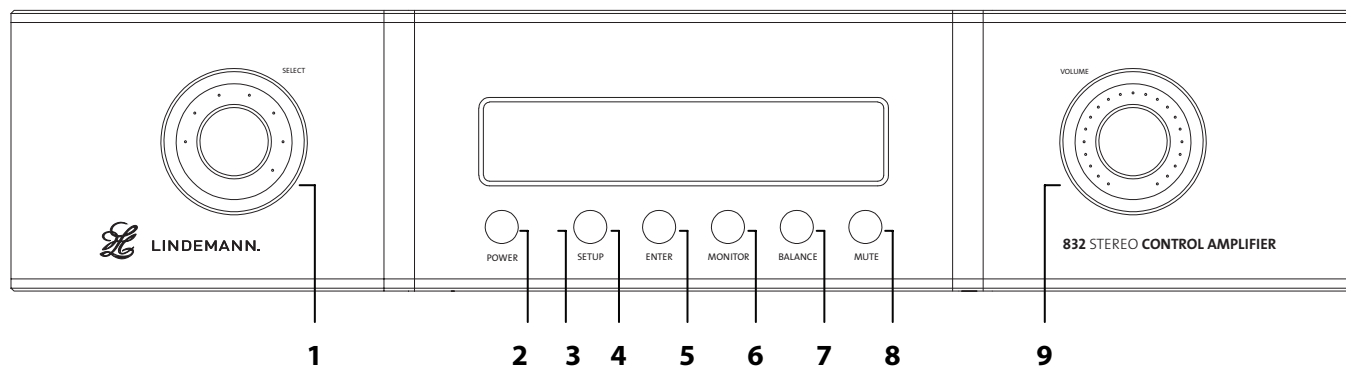

1	Input selector	6	Monitor
2	Power	7	Balance
3	Standby LED	8	Mute
4	Setup	9	Volume control
5	Enter		

### Input selector

Turn this knob to select the source you require. The operation of the input selector is described in more detail under **Basic preamplifier controls - Input selector**.

The input selector is the equivalent of the *LEFT/RIGHT* buttons on the remote control.

### Power

Press the *POWER* button to turn the unit on and off. The 832 must be connected to the mains, with the power switch on the rear panel in the 'on' position (position I).

### Standby LED

When you switch the 832 on using the power switch on the rear panel, the unit initially enters its standby mode and the standby LED illuminates. As soon as the 832 is ready for use, the standby LED extinguishes and the display becomes active. When you switch the preamplifier off, the LED flashes for approximately 5 seconds, during which time you cannot switch the unit back on again.

## Setup

This button opens the configuration menu and provides access to the more advanced preamplifier functions. To quit, press the *SETUP* button repeatedly until the standard display reappears.

## Enter

Confirm your input. This is the equivalent of the *OK* button on the remote control.

## Monitor

This button activates and deactivates the monitor circuit. Configuring the tape monitor loop is described under **Configuration menus - Monitor**.

## Balance

Adjust the soundstage balance. To quit the balance menu, press the *BALANCE* button a second time. You will find a description of how to adjust the balance in **Configuration menus - Balance**.

## Mute

Select the mute function. To cancel muting, press the *MUTE* a second time, or alter the volume.

## Volume control

The volume control knob adjusts the listening volume. Turning the knob clockwise increases the volume. The volume control is the equivalent of the *UP/DOWN* buttons on the remote control.

## Rear view

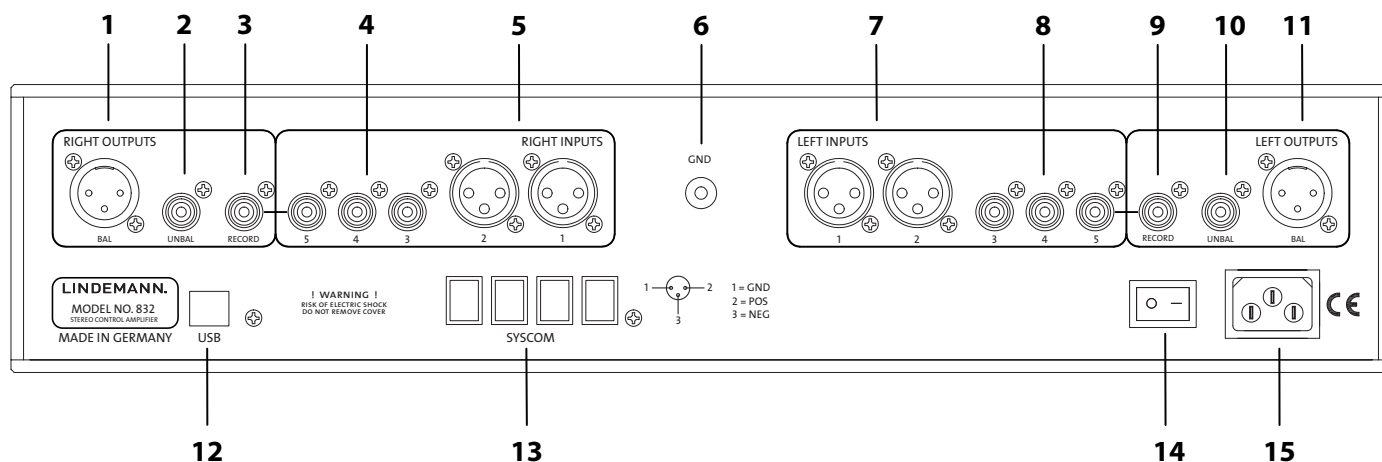

1	Analog output 2 XLR right	9	RECORD output left
2	Analog output 1 XLR right	10	Analog output RCA left
3	RECORD output right	11	Analog output XLR left
4	Inputs 3-5 RCA right	12	USB port (maintenance only)
5	Inputs 1-2 XLR right	13	SYSCOM
6	Phono ground	14	Power (on/off) switch
7	Inputs 1-2 XLR left	15	AC power socket
8	Inputs 3-5 RCA left		

## Analog inputs

The 832 is equipped with both balanced (XLR) and unbalanced (RCA phono) analog inputs. Connect the outputs from your source equipment to the appropriate inputs on your preamplifier.

Make sure that the plugs are a snug fit! Poorly fitting RCA plugs can detract considerably from the sound quality of your hi-fi system. Use gold-plated plugs whenever possible, as these have the lowest contact resistance.



- Pin 1: Ground
- Pin 2: Signal +
- Pin 3: Signal -

## Analog output

The 832 is equipped with balanced (XLR) and unbalanced (RCA) analog outputs. Connect these to the appropriate inputs on your power amplifier.



- Pin 1: Ground
- Pin 2: Signal +
- Pin 3: Signal -

## Record output

The record output enables you to send the currently active input to a tape recorder or the soundcard of your PC. The record output signal is the same level as the input signal.

The record output also offers an off-tape monitor facility. Configuring the tape monitor facility is described under **Configuration Menu – Monitor**.

## Phono ground

External system ground connection, which can be used, for example, to connect a turntable's ground cable.

## Power switch

The power switch fully disconnects the 832 from the AC mains supply.

## SYSCOM

SYSCOM allows you to network several 800 Series components (Link mode). It provides central control of switch-on and the display functions and allows the system preamplifier to access the digital inputs on the 820 CD/SACD-Player. To use this facility, you must be using the appropriate power amplifiers or CD/SACD player. Please ensure that **all** system components are switched off before changing any SYSCOM connections. Use only the SYSCOM cables supplied. Do not use any other type of cable, as this could damage your equipment! If you need longer SYSCOM cables, please contact Lindemann audiotechnik directly (see back page for contact details) or your dealer. You will find a detailed description of all Link Mode functions in the Link Mode section of this manual.

## Remote control

### 1. Power button

Switches the unit on and off from standby.

### 2. Menu selection

Selects the preamplifier's configuration menu.

### 3. Mute

Reduces the level of the outputs to zero.

### 4. Navigation cluster

#### Normal operation:

UP/DOWN: Volume adjustment +/-

LEFT/RIGHT: Input selection

OK: Confirms your selection

#### Menu selection:

UP/DOWN/LEFT/RIGHT: Selects menu items

OK: Confirms your selection

### 5. Info

Press the INFO button to see all the important basic settings in the alpha-numeric display.

When using the remote control, always point it directly at the Control Amplifier. Please remember that direct sunlight or artificial light (particularly fluorescent lighting) can affect the signal.

If you notice a decrease in the range of the remote control, this is normally a sign that the batteries are weak. Always replace batteries with new ones of the same type.

To change the batteries, open the battery compartment cover on the rear of the remote handset. Take out the discharged batteries and replace them with new ones of the same type (Alkaline AAA), making sure that they are positioned as shown on the drawing in the battery compartment.

Please dispose of your used batteries carefully. Stores that sell batteries should provide containers for the collection of used batteries. You can also dispose of them at your nearest recycling centre.

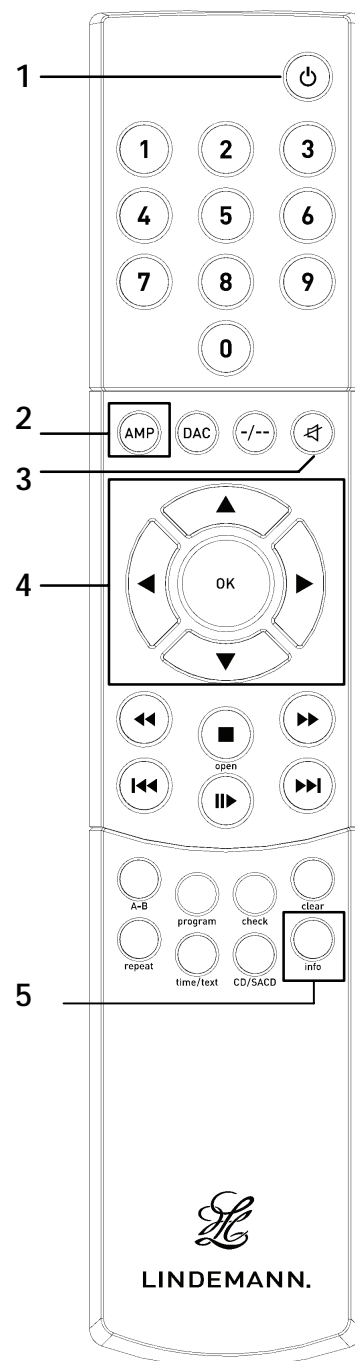

## Using the 832 for the first time

- Turn the power switch (on the rear panel) to its off position.
- Connect the control amplifier to a wall outlet using a high quality power cord if possible. The cable supplied is for test purposes only. We strongly recommend that you use a high quality power cable. Make sure that the voltage shown on the model identification plate matches the voltage of your mains supply. If you intend to swap interconnects at any time in the future, always remember to switch the control amplifier off first. Failure to do so could damage the unit.
- Please note: the 820 SACD-Player is to be connected to input 2 of the control amplifier. This is mandatory to use the digital inputs select feature of the 830. Input 1 is normally used as an input for turntable preamplifiers.
- For safety reasons, the remote control is supplied without the batteries installed. Please insert the batteries supplied, observing the polarity marks shown on the battery compartment.
- We have provided controls on the front panel to allow you to access the important control functions of the 832. The remote control allows you to access these and all the other functions of the unit.
- Switch on the unit using the power switch on the rear panel. Your control amplifier is now in standby mode and ready for use. This is indicated by the blue Standby LED.

## Basic preamplifier controls

### Switching on and off

To switch the unit on, press the *POWER* button on the front panel or on the remote control.

To switch the control amplifier off, press the *POWER* button a second time. This will switch the unit into standby mode. You will see the message: *Power Down...* in the display.

After a short interval this will disappear and the blue standby LED will flash for about 5 seconds. It is not possible to switch the component on again during this time.

Use the *POWER* button to switch the unit on and off in everyday use. If the control amplifier is connected to a Lindemann power amplifier and/or CD player, the power amplifier and/or CD player will be powered up and down at the same time as the preamplifier.

### Input select

Remote control:

Use the *LEFT/RIGHT*- button to select the signal source.

Front panel:

Turn the input selector knob to select the signal source.

If you have deactivated certain inputs using the *Input Enable* menu option, these will not be shown and cannot be selected.

If the tape monitor loop is active, you cannot select Input 5, as this is used as the monitor input.

If you have connected an 820/822 CD/SACD player via SYSCOM, you can now access the 820's four digital inputs from the 832 (inputs 6-9). To use these digital inputs, you must connect the balanced analog output on the 820/822 to Input 2 on the 832. When you select a digital input on the 832, the blue LED for Input 2 (analog input) illuminates **together with** the yellow LED to indicate that a digital input is active. The name of the digital input on the 820/822 is retrieved and displayed by the 832.

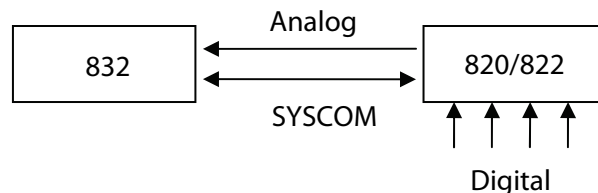

## Adjusting the volume

To adjust the volume, use the *UP* or *DOWN* buttons on the remote control, or the volume control knob on the front panel. When adjusting the volume with the remote, the speed of adjustment depends on how long you keep your finger on the *UP/DOWN* buttons. The volume control provides an adjustment range of 60 dB in 0.5dB steps. The actual volume setting will appear in the display for several seconds in figures or dBs (depending on the settings). To quit volume adjustment, press the *OK* button.

When *Min* appears in the display, you have reached the lower volume adjustment limit. When *Max* appears in the display, you have reached the upper volume limit.

You can reduce the maximum volume setting by up to 20dB using the *Max. Volume* menu. This menu allows you to adjust or limit the volume adjustment range to suit your normal listening levels.

## Balance

You will find a description of how to adjust the balance in **Configuration menus – Balance**.

## Mute

You can activate the *mute* function by pressing the MUTE button on the remote control. To cancel muting, press the *MUTE* button a second time, or alter the volume.

## Configuration menu

The 832 provides many adjustment options in addition to the basic controls. You can access these functions in *AMP Setup*. To open the menu, press the *AMP* or *Setup* buttons. To navigate within Setup, use the *LEFT* or *RIGHT* buttons on the remote control, or use the input selector on the front panel. Press the *OK* or the *ENTER* button to confirm a setting. The new setting will then be applied. In the menu you can use the Setup button to navigate back, i.e. to move back one level without changing any settings. To quit Setup, press the Setup button repeatedly until the standard display reappears.

The available settings are shown as follows:

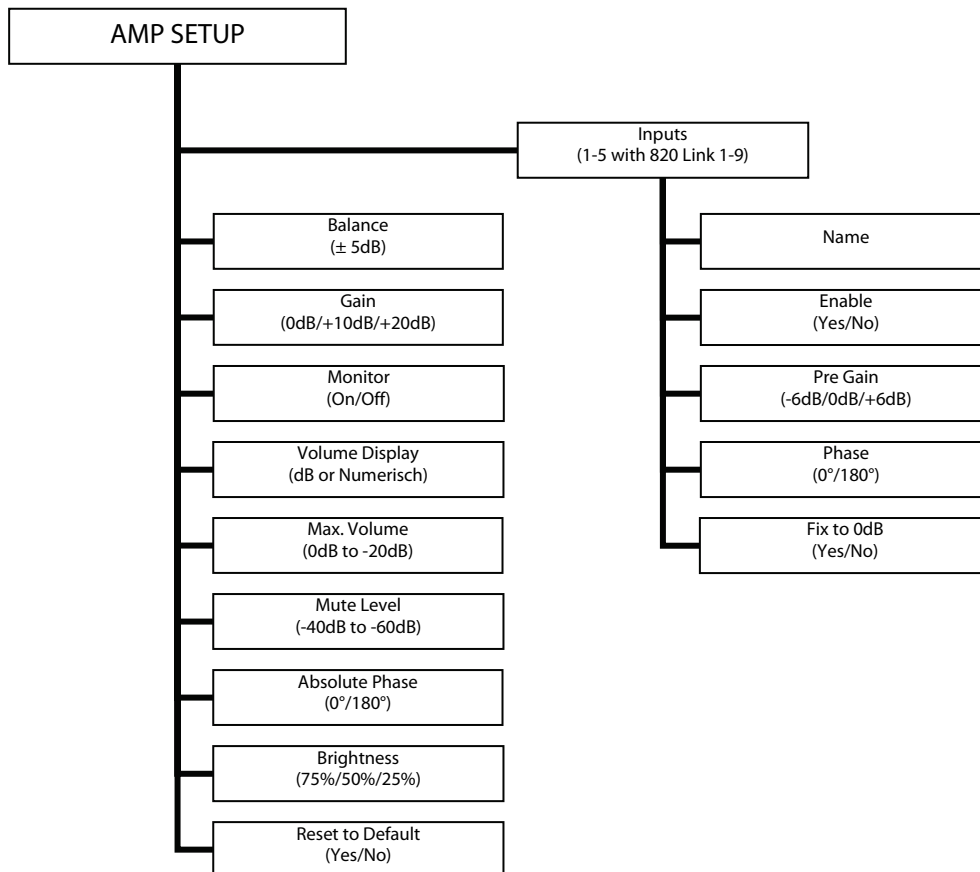

## Balance

Adjust the balance with the *LEFT* or *RIGHT* button on the remote, or the input selector knob on the front panel. The balance can be adjusted to the left or right in ten steps. The centre is the neutral setting. One step alters the balance by 0.5 dB. The maximum available adjustment is  $\pm 5$  dB. Press *OK* to confirm your selection.

## Gain

The output level of the 830 can be adjusted to match the input sensitivity of different power amplifiers. The gain settings available are 0dB, 10dB und 20dB. Important! Setting the output level too high may drive the power amplifier into clipping (distortion), which can damage your loudspeakers.

## Monitor

The 832 offers a tape loop for off-tape monitoring or for connecting an external equalizer.

The tape monitor loop is activated by pressing the *Monitor* button on the front panel or in *Setup*. The monitor loop is active only when Input 5 has been activated via the *Enable Monitor* menu option. The word *Monitor* appears in the display when the tape monitor is active.

Important! If you select the Monitor input and there is no tape recorder with tape monitoring capability connected to Input 5, you will not hear anything.

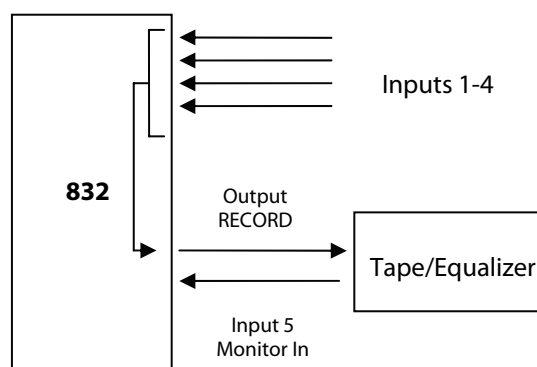

## Volume Display

You can display the volume either as a number or in dBs. In *Numeric* mode, the volume is shown from 0 to 60. In *Decibel* mode, the volume is shown from -60 to 0dB. Choose the type of display you prefer using the *LEFT* or *RIGHT* buttons. Press *OK* to confirm your selection.

## Max. Volume

*Max. Volume* lets you limit the maximum listening volume anywhere between 0dB (max. volume) and -20dB (party setting/child-proofing). Set the maximum volume in 0.5dB steps using the *UP* or *DOWN* button. Press *OK* to confirm your selection.

## Mute level

Set the mute level in 0.5dB steps using the *UP* or *DOWN* button. Press *OK* to confirm your selection.

## Absolute Phase

Certain recordings sound better when you reverse the polarity of the audio signal, although the difference is minimal with most recordings.

Set the phase of the analog output signal to 0° or 180° using the *LEFT* or *RIGHT* button. Press *OK* to confirm your selection.

## Display Brightness

When you start using the 832, its display is set to maximum brightness. After about 15 seconds, the display changes to the brightness setting you have specified in the display brightness menu. To avoid wearing out the display prematurely, do not set the display brightness too high.

You can choose three brightness levels (75%, 50% or 25%) using the *LEFT* or *RIGHT* buttons. Press *OK* to confirm your selection.

## Reset to default (factory settings)

Use this option to restore the configuration menu to the standard settings. To carry out a reset, choose *Yes* following the warning message, and confirm with the *OK* button.

## Inputs

In addition to the general configuration described earlier, which works equally on all inputs, you also have the option of adjusting individual inputs to match different signal sources.

### Name (input name)

You can assign whatever name you wish to the inputs. Press the *LEFT* or *RIGHT* button to select the desired input (1-5) and confirm by pressing *OK*. An *A<* will now appear in the display, at which point you can enter the name you want to use. Use the *UP* or *DOWN* button to select letters or special characters. Use the *LEFT* or *RIGHT* button to move to the letter you wish to change. Names may be up to 8 characters in length. Once you have finished entering the name, confirm it with the *OK* button.

If you have an 820/822 connected to your system (SYSCOM), the names of its digital inputs will appear on the 832. You can only change the names of the digital inputs via the *DAC* menu on the 820/822.

### Enable (activating inputs)

It is always advisable to disable any inputs that are not being used. When selecting inputs, any input that has been disabled will be skipped.

### Pre Gain (input sensitivity)

You can assign a different input sensitivity to each input. This can be useful when your source components have different output levels. The sensitivity settings are -6dB, 0dB and +6dB and the maximum permissible input voltage for the 0dB setting is 6.0V.

## Phase

You can swap the absolute phase setting ( $0^\circ$  or  $180^\circ$ ) of each input to compensate for the phase characteristics of individual sources and to avoid having to re-solder balanced interconnect cables to account for different pin allocations.

## Fix to 0dB (bypass)

The *Fix to 0dB* feature simplifies the integration of the 832 within a home cinema system. It allows you to switch each input individually to a 0dB mode in which the signal is passed from input to output without either gain or attenuation.

When you assign *Fix to 0dB* to an input, it passes through the preamp without any change in level. When you switch to another input, the preamplifier will use the last gain setting you used.

This feature is useful if you wish to use the stereo channels from a surround sound decoder as the front channels. The gain is then controlled by the decoder.

## Link Mode

The 832 is able to communicate with other compatible Lindemann components via SYSCOM. This Link Mode allows a single remote control to be used for all Lindemann components.

To use this feature, all components must be linked with a SYSCOM cable (see diagram below). You must switch off all components before changing any SYSCOM connections, as a re-start is required to ensure that the system recognizes all of the components.

**Important:** You can only control the 820/822 CD player and 832 preamplifier with the same remote control when Link Mode is active; otherwise, both components could react simultaneously to commands such as volume, etc. The two components should be positioned directly adjacent to or above and below each other to ensure that both remote sensors receive commands from the system remote at the same time.

The possible SYSCOM connections are:

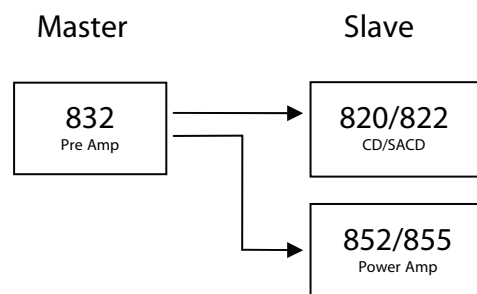

# Troubleshooting

## **The display is dark and the unit does not work:**

- The 832 is in standby mode. -> Press the *POWER* button.
- The 832 is not connected to a power outlet, or the power switch (on the rear panel) is in the off position. -> Plug the 832 into a power outlet and switch the unit on.

## **The display illuminates but there is no sound:**

- The volume setting is too low. -> Turn up the volume.
- There is no signal from the source component or the wrong source has been selected.
- The unit is in Mute mode. -> Press the *MUTE* button.
- The *Max Volume* setting is too low. -> Increase the *Max Volume* setting in the configuration menu.
- The *Tape monitor* loop is active (*Monitor* appears in the display), but there is no signal to Input 5 (monitor input).

## **The unit does not respond to the remote control.**

- The remote control batteries are discharged or have been inserted incorrectly. -> Change the batteries.
- The distance, or angle, between the remote control handset and the 832 is too great.
- The IR receiver on the 832 is obstructed. -> Make sure that there is clear line of sight between the remote control and the IR receiver.

## Specification

Measuring conditions: 22°C, 230V supply voltage.

Dimensions.....	440*105*360 mm (W*H*D incl. feet)
Weight.....	8.7 kg
AC supply.....	230 V 50/60 Hz
Power consumption.....	15 W maximum

### Analog Outputs:

Gain.....	0dB/+10dB/+20dB
Frequency response .....	1Hz – 500 kHz (-3dB)
THD .....	<0.0001% @ 1V output/<0.0005% @ 5V output
S/N (A-weighted).....	>120 dB @ 5 V output
Crosstalk L>>R .....	>120 dB @ 1 kHz
Crosstalk inputs .....	>100 dB @ 1 kHz
Maximum output voltage.....	10 V balanced/ 5V unbalanced
Output impedance.....	20 Ohms balanced/10 ohms unbalanced

### Analog Inputs:

Input impedance bal.....	5kOhm @ +6dB/10kOhm @ 0dB/20kOhm @ -6dB
Input impedance unbal. ....	2.5kOhm @ +6dB/5kOhm @ 0dB/10kOhm @ -6dB
Pre-Gain (inputs) .....	-6dB/0dB/+6dB
Maximum input voltage.....	3V @ +6dB/6V @ 0dB/12V @ -6dB

### Volume Control:

Adjustment range.....	60.0 dB
Step size.....	0.5 dB
Adjustment range Balance .....	±5 dB
Level accuracy .....	±0.05 dB
Channel balance.....	<0.05 dB

Please note:

Our product policy is one of continuous development. Specifications are therefore subject to change without notice.

## CE declaration of conformity

Product type: Preamplifier  
Model: 832 Stereo Control Amplifier

LINDEMANN audiotechnik GmbH declares that this product complies with the Low Voltage Directive 73/23/EEC and the Electromagnetic Compatibility Directive 89/336/EEC, amended by the directives 92/31/EEC and 93/68/EEC.

The conformity of the designated product with the provisions of directive number 73/23/EEC (LVD) is proved by full compliance with the following standards:

EN 60065 (Date of issue 1998)

The conformity of the designated product with the provisions of directive number 89/336/EEC (EMC) is proved by full compliance with the following standards:

EN 55013 (Date of issue 2001)

EN 55020 (Date of issue 2002)

## Guarantee and Service

At Lindemann we value our customers. When a Lindemann product leaves our factory we do not see this as the last step of the process, rather it is the beginning of our long-standing relationship with you. Thereafter we seek to support you in every way that we can. Should you require any further information feel free to contact us at Lindemann audiotechnik.

This product is guaranteed under the conditions that apply in the country of purchase and your statutory rights are not limited. In addition to any statutory rights you may have, Lindemann undertake to replace any parts that have failed due to faulty manufacture. To help us, please ask your Lindemann retailer about the Lindemann warranty scheme in operation in your country.

In parts of Europe and some other markets, extended warranty may be available to customers who register their purchase with the local Lindemann distributor. A warranty registration card is included with the product and should be stamped by your retailer and returned to the local distributor as soon as possible.

### Warning

Unauthorised servicing or dismantling of the product invalidates the manufacturers warranty. There are no user serviceable parts inside the product and all enquiries relating to product servicing should be referred to authorised retailers only.

### Technical support and information

For technical support, product queries and information, please contact either your local retailer, the local Lindemann distributor or Lindemann audiotechnik. Full details of your local distributor can be found on the Lindemann website: [www.lindemann-audio.de](http://www.lindemann-audio.de)

### Important

- Please keep a copy of the sales receipt to establish the purchase date of the product.
- Please ensure that your equipment is insured by you during any transit or shipment for repair.

### Lindemann audiotechnik GmbH

Carl-Benz-Straße 12

D-82205 Gilching

Germany

Tel: +49 (0)8105-7785-30

Fax: +49 (0)8105-7785-55

Website: [www.lindemann-audio.de](http://www.lindemann-audio.de)

E-mail: [info@lindemann-audio.de](mailto:info@lindemann-audio.de)

[service@lindemann-audio.de](mailto:service@lindemann-audio.de)

## Directive on waste electrical and electronic equipment

Electronic equipment should not be disposed of with household waste but in compliance with the Directive 2002/96/EU of the European Parliament and of the Council of 27 January 2003 on waste electrical and electronic equipment. When this equipment reaches the end of its working life, please take it to one of the available collection points.

The symbol (below) is attached to this product.



